

DOOSAN INFRACORE GENERATOR ENGINE

DP222CB

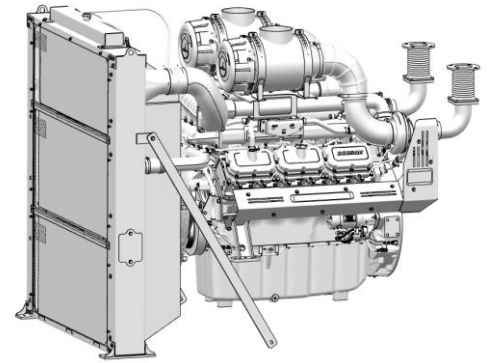

| Ratings (kWm/PS) | Gross Engine Output | | | Net Engine Output | | |
|----------------------|---------------------|----------|---------|-------------------|----------|---------|
| | Standby | Prime | COP | Standby | Prime | COP |
| 1500rpm(50Hz) | 790/1074 | 705/959 | 501/681 | 769/1045 | 684/930 | 480/652 |
| 1800rpm(60Hz) | 890/1210 | 810/1101 | 578/786 | 853/1160 | 773/1051 | 541/736 |

Ratings Definitions

The power ratings of Emergency Standby and Prime are in accordance with ISO 8528. Fuel Stop power in accordance with ISO 3046. Electric power (kWe) must be considered cooling fan loss, alternator efficiency, altitude derating and ambient temperature.

STANDBY POWER RATING is applicable for supplying emergency power for the duration of the utility power outage. No overload capability is available for a standby rated engine should be sized for a maximum of an 80% average load factor and 200 hours of operation per year. This includes less than 25 hours at the Standby Power rating.

PRIME POWER RATING is available for an unlimited number of hours per year in variable load application. Variable load should not exceed a 70% average Prime Power rating during any operating period of 24 hours. The Total operating time at 100% Prime Power shall not exceed 500 hours per year. A 10% overload capability is available for a period of 1 hour within a 12 hour period of operation. Total operating time at the 10% overload power shall not exceed 25 hours per year.

CONTINUOUS POWER is defined as being the maximum power which the generating set is capable of delivering continuously whilst supplying a constant load when operated for an unlimited number of hours per year under the agreed operating conditions with the maintenance intervals and procedures being carried out as prescribed by the manufacturer

© GENERAL ENGINE DATA

| | |
|-------------------------------|--|
| ○ Engine Model | DP222CB |
| ○ Engine Type | 4-Cycle, V-Type, 12-Cylinder Diesel, water cooled, Turbo charged & intercooled |
| ○ Bore x stroke | 128 x 142 mm |
| ○ Displacement | 21.927 liters |
| ○ Compression ratio | 14.6 : 1 |
| ○ Rotation | Counter clockwise viewed from Flywheel |
| ○ Firing order | 1-12-5-8-3-10-6-7-2-11-4-9 |
| ○ Speed drop | G3 Class (KS R ISO 8528-5) |
| ○ Injection timing | Controlled by ECU |
| ○ Dry weight | 1,676 Kg (W/O Fan) |
| ○ Dimension (LxWxH) | 1,658 x 1,593 x 1,701 mm |
| ○ Fly wheel housing | SAE NO.0 (18 Inch.) |
| ○ Fly wheel | Clutch NO.18M |
| ○ Number of teeth on flywheel | 117 |

© ENGINE MOUNTING

Maximum Bending Moment at Rear Face to Block 1290 N · M

© EXHAUST SYSTEM

Maximum Back Pressure 5.9 kPa

© AIR INDUCTION SYSTEM

Maximum Intake Air Restriction

. With Clean Filter Element 2.2 kPa

. With Dirty Filter Element 6.2 kPa

○ Max. static pressure after Radiator 0.13 kPa

◎ COOLING SYSTEM

Water circulation by centrifugal pump on engine.

| | |
|---------------------------------|---|
| ○ Cooling method | Fresh water forced circulation |
| ○ Coolant capacity | Engine Only : Approx. 24 lit., With Radiator : Approx.66 lit.(standard) |
| ○ Coolant flow rate | 737 liters / min @1800 rpm, 623 liters / min @1500 |
| ○ Pressure Cap | 90 kPa |
| ○ Water Temperature | |
| - Maximum for standby and Prime | 103°C |
| - Before start of full load | 40.0°C |
| ○ Water pump | Centrifugal type driven by Pulley |
| ○ Thermostat Type and Range | Wax – pellet type, Opening temp. 71°C , Full open temp. 85°C |
| ○ Cooling fan | Blower type, Plastic, 1,150 mm diameter, 8 blade |

◎ LUBRICATION SYSTEM

Force-feed lubrication by gear pump, lubricating oil cooling in cooling water circuit of engine.

| | |
|---------------------------|---|
| ○ Lub. Method | Fully forced pressure feed type |
| ○ Oil pump | Gear type driven by crank-shaft gear |
| ○ Oil filter | Full flow, cartridge type |
| ○ Oil capacity | Max. 75 liters , Min. 23 liters |
| ○ Lub oil pressure | Idle Speed : Min 100 kPa Governed Speed : Min 300 kPa |
| ○ Maximum oil temperature | 120°C |
| ○ Angularity limit | Front down 10 deg , Front up 10 deg , Side to side 15 deg |
| ○ Lubrication oil | SAE 10W40(API CI-4 Grade) |

◎ FUEL SYSTEM

Bosch electronic high pressure fuel pump and controlled by ECU

| | |
|------------------------------------|--|
| ○ Injection pump | Bosch C/Rail Pump |
| ○ Feed pump | Gear type |
| ○ Injection nozzle | Multi hole type |
| □ Max. Injection pressure | Max. 1800bar |
| ○ Fuel filter | Main (On Engine) : Full flow, High efficiency dust in fuel filter, cartridge type Pre(Loosed Part) : Full flow, cartridge type with water drain valve |
| ○ Fuel Inlet Pressure Requirement | 0.5~1bar(Abs.) |
| ○ Fuel Outlet Pressure Requirement | 0~1.2bar(Abs.) |
| ○ Fuel feed pump Capacity | 386 liters / hr @ 1500 rpm(engine), 464 liters / hr @ 1800 rpm(engine) |
| □ Allowable fuel | Domestic : Korean Ultra Low Sulfur Diesel, Europe : EN590: 2013/AC:2014 North America : ASTM D975C-15 Grades 1D or 2D, Japan : JIS K2204:2007 |

◎ ELECTRICAL SYSTEM

| | |
|-------------------------------|--|
| ○ Battery Charging Alternator | 24V x 45A Alternator |
| ○ Voltage regulator | Built-in type IC regulator |
| ○ Starting motor | 24V x 7.0 kW |
| ○ Battery Voltage | 24V |
| ○ Battery Capacity | 4 x 200 Ah (Minimum specification, 12V 4ea Series-parallel connection) |
| ○ Starting aid (Option) | Block heater, Air heater |

◎ VALVE SYSTEM

| | | |
|------------------------|----------------------------------|----------|
| ○ Type | Overhead valve type | |
| ○ Number of valve | Intake 2, exhaust 2 per cylinder | |
| ○ Valve lashes at cold | Intake 0.4mm , Exhaust 0.7mm | |
| ○ Valve timing | Opening | Close |
| - Intake valve | 35° BTDC | 31° ABDC |
| - Exhaust valve | 62° BBDC | 25° ATDC |

◎ PERFORMANCE DATA

| | | Prime | | Standby | | COP | | |
|---|-----------|-----------|-------|---------|-------|-------|-------|-----|
| ○ Governed Engine speed | rpm | 1,500 | 1,800 | 1,500 | 1,800 | 1,500 | 1,800 | |
| ○ Engine Idle Speed | rpm | 750 | 750 | 750 | 750 | 750 | 750 | |
| ○ Over speed limit | rpm | 1,650 | 1,980 | 1,650 | 1,980 | 1,650 | 1,980 | |
| ○ Gross Engine Power Output | kW | 705 | 810 | 790 | 890 | 501 | 578 | |
| | ps | 959 | 1101 | 1074 | 1210 | 681 | 786 | |
| ○ Break Mean effective pressure | Mpa | 2.6 | 2.5 | 2.9 | 2.7 | 1.8 | 1.8 | |
| ○ Mean Piston Speed | m/s | 7.1 | 8.5 | 7.1 | 8.5 | 7.1 | 8.5 | |
| □ Friction Power | kW | 52 | 75 | 52 | 75 | 52 | 75 | |
| | ps | 71 | 102 | 71 | 102 | 71 | 102 | |
| ○ Specific fuel consumption | | | | | | | | |
| | 25% load | liters/hr | 50 | 60 | 63 | 73 | 38 | 48 |
| | 50% load | liters/hr | 93 | 117 | 102 | 117 | 74 | 84 |
| | 75% load | liters/hr | 127 | 155 | 146 | 166 | 102 | 117 |
| | 100% load | liters/hr | 168 | 204 | 190 | 216 | 128 | 145 |
| ○ Fan Power | kW | 21 | 37 | 21 | 37 | 21 | 37 | |
| ○ Sound Pressure at 1m from the each side of Cylinder Block | | | | | | | | |
| (with Fan) | dB(A) | 98 | 102 | 98 | 101 | 97 | 101 | |

The all data and the specific fuel consumption are based on ISO 3046/1, Standard reference conditions are in accordance with 298 K(25° Celsius) air temperature, 100kPa(1000mbar) air pressure, 60% relative humidity, 110m(361ft) altitude.

The sound pressure evaluation method follows ISO3744

Engine Data with Dry Type Exhaust Manifold

| | | | | | | | |
|----------------------------------|------------|------|------|------|------|------|------|
| ○ Intake Air Flow | m3/min | 44 | 58 | 48 | 61 | 34 | 46 |
| ○ Exhaust gas temp. after turbo. | °C | 520 | 455 | 525 | 470 | 510 | 435 |
| ○ Exhaust Gas Flow | m3/min | 123 | 143 | 136 | 152 | 93 | 114 |
| ○ Heat Rejection to Exhaust | kW | 536 | 586 | 598 | 641 | 439 | 442 |
| ○ Heat Rejection to Coolant | kW | 321 | 346 | 350 | 382 | 255 | 265 |
| ○ Heat Rejection to Intercooler | kW | 118 | 180 | 147 | 205 | 78 | 102 |
| ○ Radiated Heat to Ambient | kW | 38 | 45 | 43 | 48 | 32 | 33 |
| ○ Cooling water circulation | liters/min | 623 | 737 | 623 | 737 | 623 | 737 |
| ○ Cooling fan air flow | m3/min | 1266 | 1510 | 1266 | 1510 | 1266 | 1510 |

◆ ENGINE DIMENSION

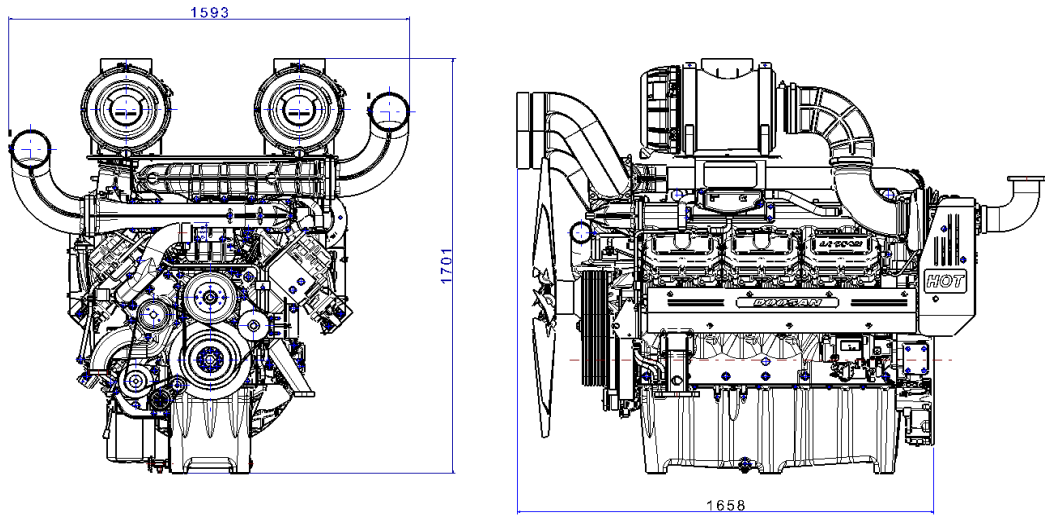

◆ CONVERSION TABLE

| | |
|------------------------------------|------------------------------------|
| in. = mm x 0.0394 | lb/ft = N.m x 0.737 |
| PS = kW x 1.3596 | U.S. gal = lit. x 0.264 |
| psi = kg/cm ² x 14.2233 | kW = 0.2388 kcal/s |
| in ³ = lit. x 61.02 | lb/PS.h = g/kW.h x 0.00162 |
| hp = PS x 0.98635 | cfm = m ³ /min x 35.336 |
| lb = kg x 2.20462 | Mpa = Pa x 1000 = bar x 10 |
| kW = Kcal/sec x 0.239 | |

Doosan Infracore Co., Ltd.

21st Floor, Doosan Tower, 18-12, Euljiro 6-ga,
Jung-gu, Seoul, Korea.

TEL : +82-2-3398-8400 / FAX : +82-2-3398-8509

E-mail : enginesales@doosan.com

Web site : www.doosaninfracore.com

※ Specifications are subject to change without prior notice